

UNICORD-CH-01A

**Type1
Portable
EV Charger**



ICON Display Design

(with Touch Switch)

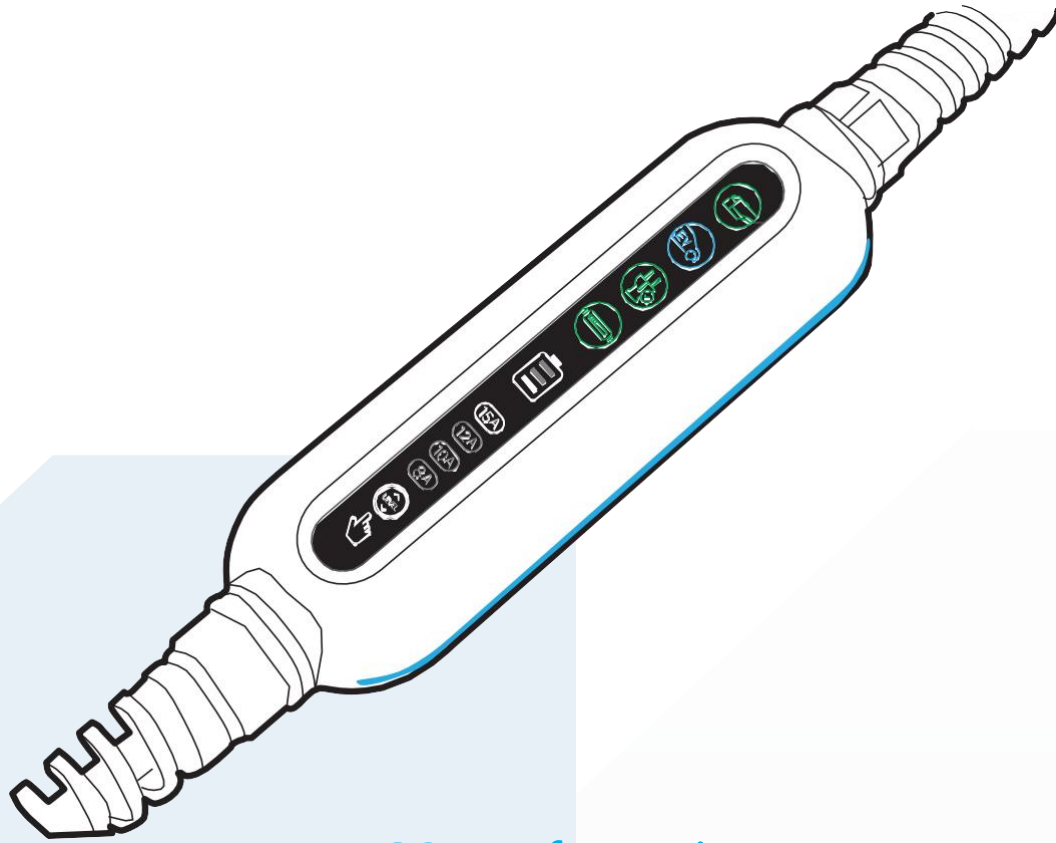

ICON Information

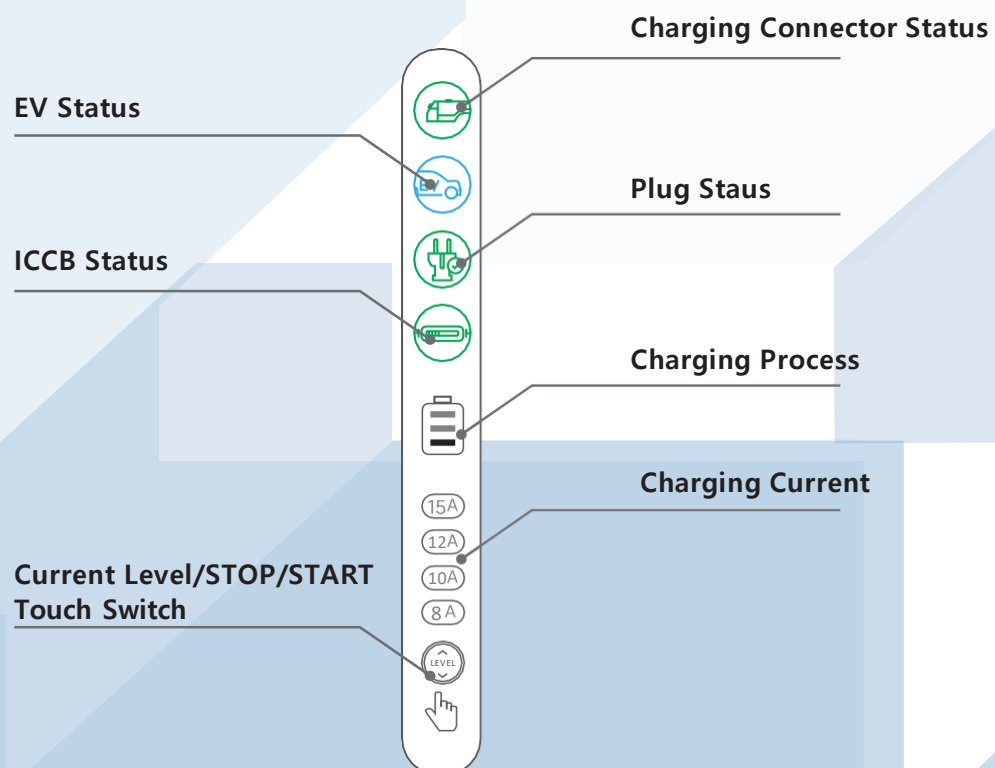

Status Indicate

(by Side Edge 3-Colors LED Bar & ICON)

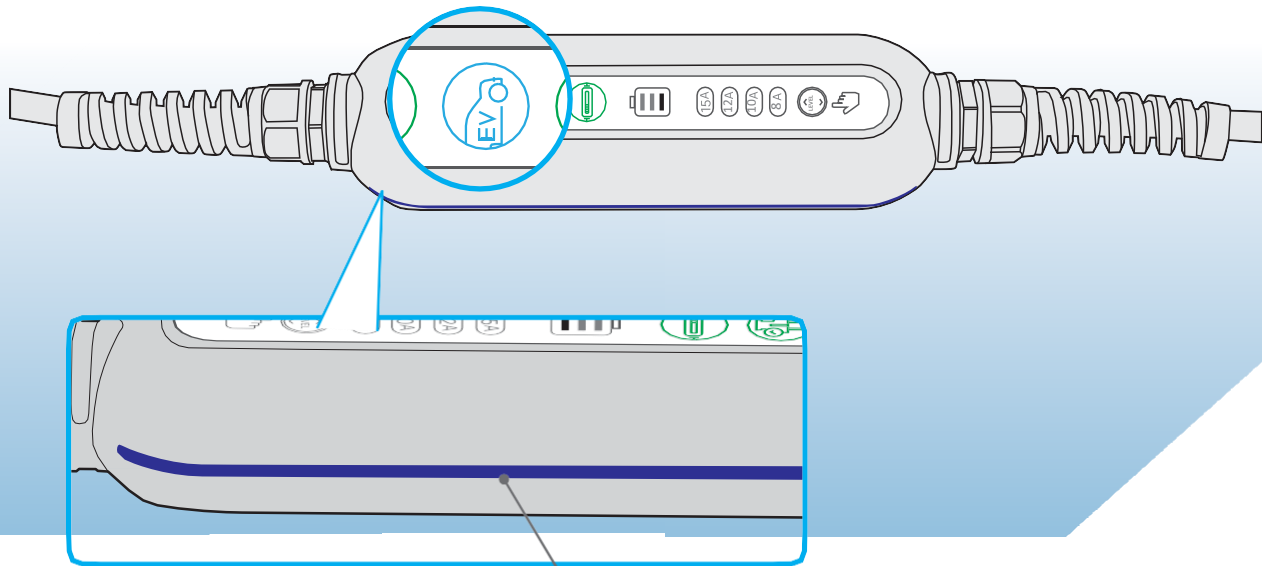

- Green bar: Stanby
- Red bar: Error
- Blue bar: Charging

ICON Status Example

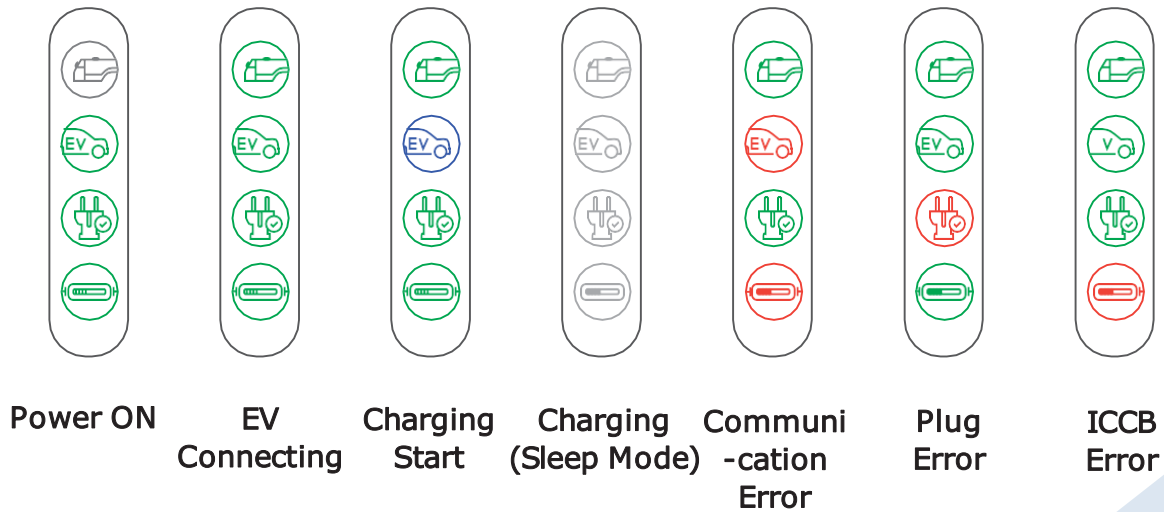

Trendy Slim Design

Fit & Easy to Grip

- Advanced Grip (Surface SF Coating)
- Lightweight & Slim Structure
(Ultrasonic Welding Body – No Bolting Holes)

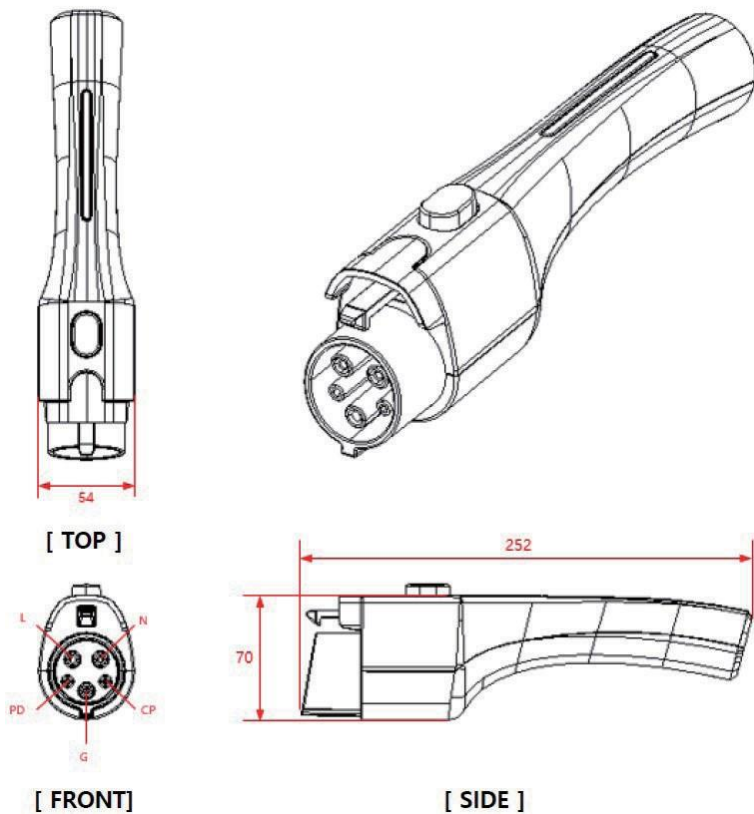

Waterproofing performance(IP55)

IP55 waterproofing/dustproof design protect product



Adopted built-in plug and temperature sensor for fire protection

When the product overheats, it automatically reduces the Charging current by plugging temperature sensor, If it exceeds the limit, it automatically shuts off the power so it prevents fire accidents.



Temperature sensor

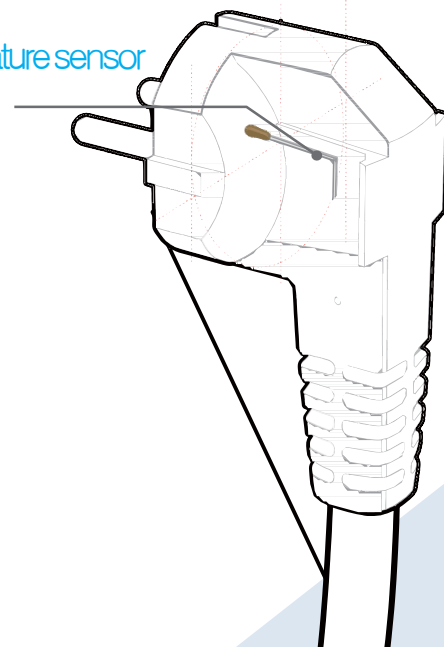

Self checking function

After self checking, it is operating and going into the charging flow.

If there is a some troubles, it will making warning sound before operating.

By using the self checking function for main parts , more strengthen the user safety.

It protects the product from overvoltage, overcurrent, and overheating, short circuit, leakage etc.

Trouble notification sound



Charging notification sound



component



Battery charger

Carrying case

Specifications&Certification

Product spec

Division		Contents
Input voltage		AC 85~265V
Rated Power		3.3kW (AC 220V / 15A)
Operating temp		- 20 ~ 50 °C
S I Z E	Length	5M / 10M / 15M
	Size(ICCB)	65mm x 225mm x 40mm
	Weight	1.5kg
Material		Poly Carbonate (flame retardant PC) + SF coating
Waterproof/dustproof		IP55
standa rd	outlet(connector)	SAE J1772, IEC62752 (Type 1)
	ICCB	IEC61851
	Power Cord	KC60884(E/F Type - temp sensor(built-in))
	EV Cable	TUV (EN50620)
Main functi on/ featu re	Current control	4steps(15A/12A/10A/8A)
	High temp sensing blocking (ICCB/plug)	Automatically control charging current when its overheating/stopping
	Leakage current blocking	20mA
	Self checking function	Self checking main electric safety parts
	Touch switch	Charging current setting /charging stopping/ charging start
Stat us LED	Operating sound	Charging current setting/charging start / emergence of trouble
	ICCB side bar	power(Green)/charging(Blue)/trouble(RED)
	ICCB TOP icon	Information display by all operating icon/ sleep mode(1min)
Charging connector	LED Blue lighting on charging	

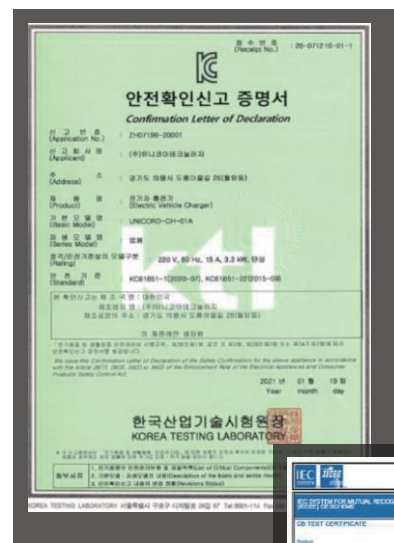

[KC Cert]



[Charger
connector
CB cert]

Manufacturer : Unicore Technology Co., Ltd.

Product : UNICORD-CH-01A (Portable electric car charger)

Homepage : ev-unicord.com

Country (Korea)

- Uiwang City Gyeonggi-do, Korea

Country (Japan)

- Rm602. Esty Masion Kayaba, 2-16-17, Kayaba,Chikusa-Ku, Nagoya City

Inquiry & AS Contact

1) Korean

Tel. : +82-01-462-5972

E-Mail : show8042427@ev-unicord.com

2) Japanese/English

Tel. : +81-80-1249-1753

E-Mail : logkwon45@gmail.com

